

System Design and Layout Guide

SYNOPSIS

Imagine a lighting system where operators easily patch DMX outlets to any combination of DMX sources: main console, moving light console, special effects console or even a handheld controller – and all active at the same time.

Imagine a future-proofed system that supports Remote Device Management (RDM) and Architecture for Control Networks (ACN) right out of the box. Imagine all of this at an installed cost of about half that of most other Ethernet-based DMX distribution systems available.

Pathway Connectivity's *Pathport®* DMX management system provides all this – and more – over a conventional Ethernet backbone.

ADVANTAGES

- Unprecedented operational flexibility – no rules!
- Address up to 128 input universes – over 65,000 channels
- Unlimited number of outputs
- Supports all major DMX-over-Ethernet protocols: Net3/streaming ACN; Pathport; Strand Shownet; ArtNet; ETC Net2 (as output)
- Custom channel routing, plus merging and prioritization – all built in
- Low cost, high performance nodes provide a competitive bid advantage for systems integrators
- LCD screen on each node allows 'soft engraving' as well as displaying DMX status and diagnostics feedback
- All one and two port nodes use Power-over-Ethernet to minimize wiring
- Cable installation, testing and certification requirements that are readily understood by a qualified communications wiring contractor
- An installation can be completely configured and commissioned by a systems integrator without special software, tools or training

TYPICAL SYSTEM

A Pathport system is, fundamentally, a method for distributing DMX512 data. Input nodes should be located wherever consoles or remotes might be positioned: in the booth, at the designer table, in the side stage or FOH. One input port is required for each universe of DMX or each DMX input source.

Output nodes should be liberally placed throughout the facility, wherever DMX may be required. Pathport I/O nodes can be located wherever both DMX input and output access points are required.

Nodes are star-wired back to one or more Ethernet switches. Using a PC, also connected to the switch, operators use *Pathport Manager* software to configure which DMX input signals get routed to which output nodes.

SYSTEM COMPONENTS

Four elements must be considered when designing a Pathport system: the Pathport nodes, the Ethernet backbone, the configuration interface and the peripheral equipment to be connected. A generic layout is shown below, with DMX signal in red and Pathport routing in blue.

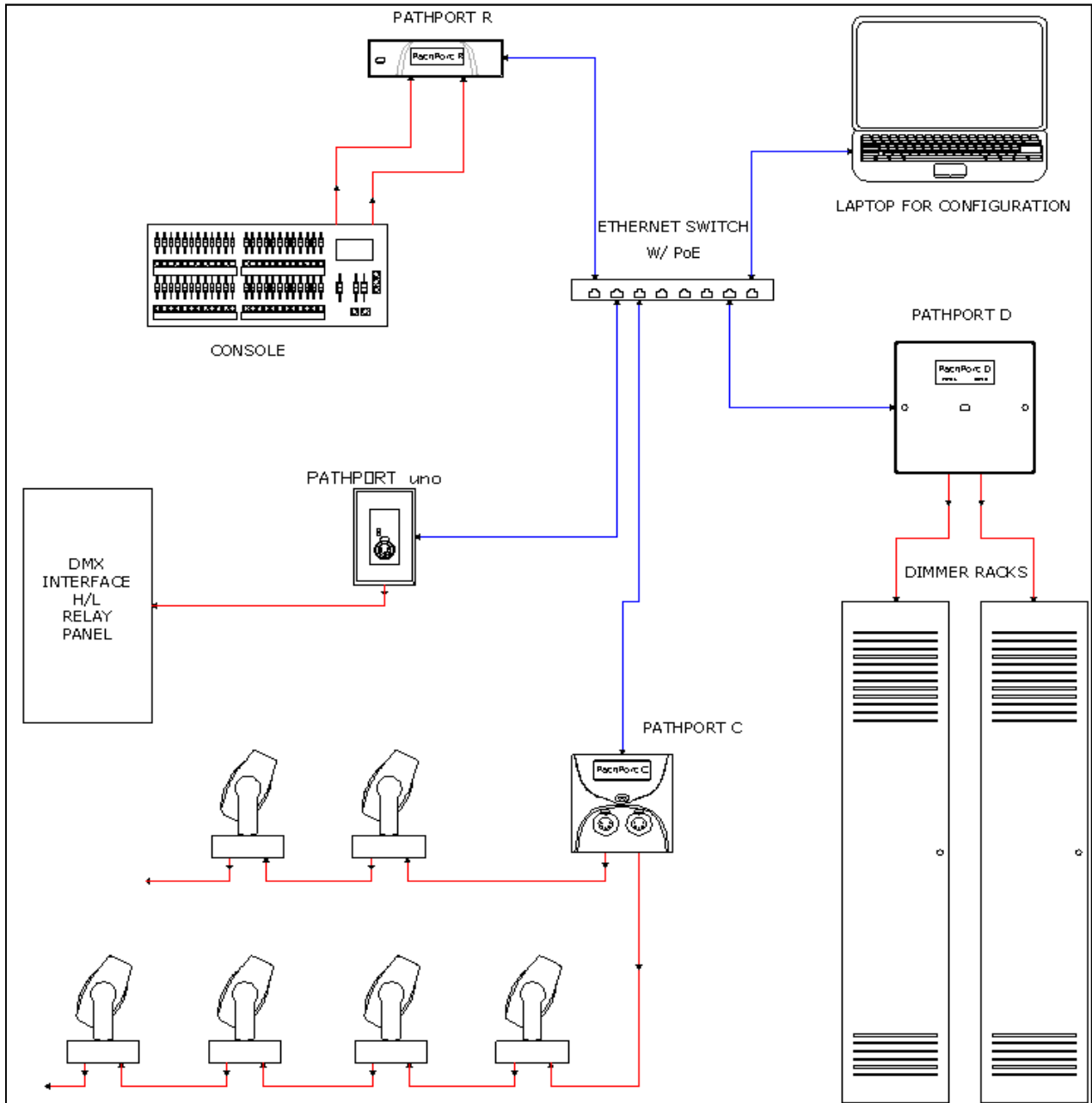

Some peripherals, especially recent control consoles, are able to plug directly into the Ethernet switch. However, designs should still include some input nodes to allow for touring consoles, test equipment and other DMX-only sources.

ETHERNET WIRING

The success of a Pathport system relies on the proper installation of the network wiring. Ethernet uses a star-wiring topology. Each device, in this case each Pathport node, is wired directly back to a central switch. By wiring switches together the network can be extended. Pathports operate at 10 and 100 megabits, so Cat5e wiring is sufficient. However, given the minor cost difference, installing Cat6 wiring (meant for gigabit networks) will provide future-proofing.

More important at the planning stage is calculation of cable lengths. Ethernet copper cable segments cannot be longer than 100m or 330 feet and standard practice is to limit them to 90m. Fiber optic backbones are used where longer runs are necessary, especially in outdoor applications. Media converters are required between the fiber and copper portions of the network and external power supplies may be necessary for the Pathport nodes.

Pathway strongly recommends the use of a certified network installer for all wiring runs. A certified installer will test all wiring and connectors and should provide a report stating the network meets the TIA/EIA-568 standard. Pathway Connectivity may refuse or curtail technical support for equipment installed on uncertified systems.

Although the hardware sections are dated, for further information on preferred topologies, and labeling practices, we suggest ESTA's **Recommended Practice for Ethernet Cabling Systems in Entertainment Lighting Applications** and its **Supplement**, both available at www.esta.org.

ETHERNET SWITCHES

The selection and configuration of the Ethernet switch is also critical to the performance of a Pathport system. In general, unmanaged or plug-and-play switches are preferable to managed or enterprise switches, as long as they do not incorporate broadcast storm control or other forms of traffic management.

DMX-over-Ethernet protocols are multi-cast or broadcast protocols where one source (typically a lighting console) sends a constant stream of information to all the output nodes. Each output node determines which bits of information to use. However, the management features of most enterprise switches are designed for the uni-cast, one-to-one traffic of an office network. Broadcast traffic is treated as an error and blocked - with disastrous effects during a show. Multi-cast filtering to direct traffic can also wreak havoc. The usual solution is to turn these features off.

If possible the lighting network should be kept separate from other traffic, such as sound networks (CobraNet, etc) or Internet traffic. If the network must be shared, VLANing may be necessary and Pathway strongly recommends hiring network specialist to specify and configure the switches for such installations.

Another key specification for the switch is Power-over-Ethernet. Most switches are now available with built-in PoE. All Pathport nodes, except the DMX Manager Plus and the Octo, run on PoE, vastly simplifying wiring requirements. Without

ETHERNET SWITCHES (cont'd)

PoE, power outlets and wall transformers will be required at each node location. Pathway has had success with the following switches (however, be aware these manufacturers may change specifications without notice):

- HP Procurve 2610-24PWR
- Netgear FS108P - 8 ports, 4 powered
- 3COM 3CDSG10PWR (fanless)

Note: A Pathway-branded switch will be shipping in spring 2011.

WIRELESS ETHERNET

Wireless Ethernet involves significant additional network considerations, including latency (transmission delay), bandwidth limitations, and network security. For best results, Pathway recommends contacting an entertainment network technology company specializing in wireless Ethernet, such as Interactive Technologies. For wireless DMX, we suggest City Theatrical.

However, the general rule still holds: Hardwire whenever possible.

ETHERNET DESIGN TIPS

- DMX-over-Ethernet only requires speeds up to 100 Mbits, but Cat6 wiring provides future-proofing
- Include at least one Ethernet access point for a laptop to run the configuration software
- Install RJ45 jacks in locations where portable or pipe-mountable nodes may be used
- Observe Ethernet wiring rules and the 100m cable segment limit
- PoE (Power-over-Ethernet) should be specified as an absolute requirement
- Hard-wiring is preferable to wireless

PATHPORT NODES

Each Pathport consists of one or more ports, with each port being independently configurable. Choose the best form factor for the job, without sacrificing features.



Pathport Uno

An elegant, single-gang backbox design provides one universe of DMX input or output, with all the soft patch features available in other styles. With unobtrusive LED indicators for DMX present and network activity, the Uno is ideal for use in public-accessible locations or where a low-cost, single port node is needed. Requires Power-over-Ethernet. The Uno offers an output-side channel patch on a Net2 system - not available anywhere else! Also available in a portable enclosure.



Pathport eDIN

A single-port node in a DIN-rail mountable form - the Pathport eDIN is ideal for enclosure use. Output is user-switchable between a standard DMX pinout and the Color Kinetics wiring scheme.

PATHPORT NODES (cont'd)

PATHPORT C - SERIES

The most popular 2-port Pathport. Fitting into a 2-gang, deep masonry box, the C-series provides flush-mounting, with surface mount or portable boxes as an option.

2-input, 2-output or input/output are available - although any port can be configured to run in either direction. The LCD screen reports if DMX is active, and can also display system-specific labels, such as node location or purpose.

Typically used wherever flush-mount is preferred, at both control and output locations, the discrete design will not seem out of place in any room.



PATHPORT D - SERIES

A surface-mount enclosure intended for retro-fits next to dimmer racks, or for installation in utility closets and other controlled access locations. Ethernet and DMX wiring can be conduit-fed straight to the box and land on integral terminal blocks inside. Provides two ports of input, output, or one of each.

PATHPORT R - SERIES

The R-series provides 2 ports in a rack-mountable form. Two Pathport R nodes will fit side-by-side within one RU of rack space making for compact installation. Rack ears are included.

Available with XLR5 or terminal block connectors, with a front connector adapters as an accessory. Truss yoke also available.

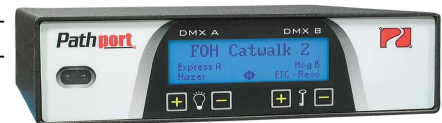

DMX MANAGER PLUS

The DMX Manager Plus is a full-featured 4-port DMX router - ideal as a gateway on or off of an Ethernet backbone. It also can act as a stand-alone DMX merger, prioritizer, and signal router. All features can be configured from the front panel or by using Pathport Manager software.



Each port has both a male and female connector with the unused connector available as a pass through. An integrated Ethernet switch allows multiple boxes to be chained together. The Manager Plus takes up one RU of space and ships with rack ears. The universal power supply accepts voltages between 85 and 240 VAC. The Manager Plus does not support Net2.

PATHPORT NODES (cont'd)



Pathport Octo

The newest Pathport model, the Octo offers eight ports of input or output or any combination in between. With all the features and flexibility Pathports are renowned for, the one RU design is also the perfect building block for replacing aging Pathfinder systems.



Pathport Touring Edition

The Pathport TE fills a need in the rental and touring markets for a robust one-port node. Sporting an IP54 rating and a battery-powered user interface, all input and output parameters are easily configured using just three buttons. DMX and RDM testing tools are also accessible from the front panel, eliminating the need to boot up a computer to trouble shoot a rig.

PATHPORT DESIGN NOTES

- Include enough Pathport input nodes for the anticipated maximum number of DMX sources—up to 128 input universes are possible
- Each output can merge/prioritize up to 8 input universe streams
- Specify 2-gang deep masonry boxes for C-Series nodes
- Specify Power-over-Ethernet for systems using one and two-port nodes
- Pathport nodes support all major DMX-over-Ethernet protocols: Net3/streaming ACN; Pathport; Strand Shownet; ArtNet—so the choice of console isn't dictated by the DMX distribution
- All one and two-port nodes support Net2 (as outputs)
- Choose the best form for the job—without sacrificing features
- Each port on any node can be configured independently for signal direction, DMX speed, signal loss behaviour, and channel patch

CONFIGURATION

Pathport Manager 5

All Pathport nodes are easily configured using Pathport Manager 5 software - a free download from the Pathway website. Pathport Manager is a Java-based program that is operating-system independent. It will discover the nodes connected to the network and allows easy configuration of node parameters, such as IP address, node name and Ethernet transmit and receive protocols, as well as reporting the node's firmware version and signal status. Backlights can be turned on and off via the software as well.

Pathport Manager also gives access to port-specific parameters such as signal direction, channel patch and speed. Individual ports can be named according to

CONFIGURATION (cont'd)

location or use. Showfiles, including all node configuration and channel patches, can be saved and edited off-line as CSV files. Patches can be written and saved independent of the nodes, simplifying system management and changeovers between show-specific patches. DMX Console and Monitor tools facilitate signal trouble-shooting, while IP reporting and error logging help resolve network issues. Pathport Manager also manages firmware upgrades and boot-up behavior and provides configuration support to some Strand and Entertainment Technology products incorporating Pathport Ethernet technology.

The latest version, version 5, is now available on the website. Version 3 is still required to update nodes running some older firmware versions.

FIRMWARE FEATURES

- Customize each output universe using up to eight input streams
- Automatically merge different Ethernet protocols
- Crossfade between prioritized sources on loss or gain of signal, and on a user-specified time
- Streaming ACN “magic channel” allows operator to choose which source is active
- Streaming ACN input priority scheme fully supported
- Set DMX output speed on a per-port basis
- Signal loss behaviour can be set port-by-port
- Each port is able to act as RDM proxy—or disable RDM port-by-port
- Nodes accept any valid IPv4 address and subnet mask arrangement

PERIPHERALS

A Pathport system is a DMX distribution network. Once commissioned, most problems that arise are with the signal source and its show programming or with failures of the end gear. Because DMX does not have error reporting capabilities, trouble shooting is typically based on error isolation.

Most modern lighting consoles can connect directly to the nodes via the Ethernet switch, and must share the correct IP address and subnet mask configuration with the nodes in order to function correctly.

SYSTEM COMMISSIONING

Pathports arrive from the factory with a unique IP address in the 10.x.x.x domain with a class A subnet mask. By default, Port A is set to universe one, Port B is set to universe two and so on. Signal path testing is as simple as plugging a DMX source into an input port, and checking that the corresponding output ports become active, as reported on each LCD display. Commissioning is that simple.

More sophisticated or detailed configuration is readily done by connecting a computer to the network, setting the IP address of its network interface card to the 10.x.x.x domain (and subnet 255.0.0.0) and running Pathport Manager 5.

Because configuration is retained by the nodes, Pathports can easily be pre-configured in the shop prior to shipping and installation on-site. A great deal of time and expense can be saved this way.

SYSTEM COMPONENTS & LIST PRICING

Model	Model Description	MSRP
1011	eDIN Pathport Uno	\$430
6001	Single node inline power supply	75
6010	Pathport Manager Configuration Software on CD	50
6101	Pathport Uno, Single DMX input node with cover	420
6102	Pathport Uno, Single DMX output node with cover	420
6151	Pathport Uno, Single DMX input with Portable Enclosure and bracket	500
6152	Pathport Uno, Single DMX output with Portable Enclosure and bracket	500
6182	Pathport Touring Edition	520
6201	Pathport C-series node with 2 DMX inputs (XLR5M)	790
6202	Pathport C-series node with 2 DMX outputs (XLR5F)	790
6203	Pathport C-series node with 1 DMX input and 1 DMX output (XLR5M/F)	790
6225	Pathport D-series node with 2 DMX ports (terminals) and backbox	920
6235	Pathport R-series node with 2 DMX ports (terminal strips)	920
6241	Pathport R-series node with 2 DMX inputs (XLR5M)	920
6242	Pathport R-series node with 2 DMX outputs (XLR5F)	920
6243	Pathport R-series node with 1 DMX input and 1 DMX output (XLR5M/F)	920
6301	Pathway DMX Manager Plus 4-port node (XLR5)	1500
6302	Pathway DMX Manager Plus 4-port node (terminal strips)	1500
6401	Pathport Octo with rear XLR (F) (Q1–2010)	2100
6402	Pathport Octo with rear terminal strips (Q1–2010)	2100
6403	Pathport Octo with front XLR (F) (Q1–2010)	2100
6900	Uno Surface Mount Enclosure (w/ knockouts)	40
6901	C-series Surface Mount Enclosure (w/ knockouts)	60
6911	C-series Portable Enclosure with hanging bracket	110
6913	R-series Truss mount kit	60
6931	R-series front connectors adaptor kit – inputs (XLR5M)	60
6932	R-series front connectors adaptor kit – outputs (XLR5F)	60
6933	R-series front connectors adaptor kit – input/output (XLR5M/F)	60
6950	RJ45 female in-line mini-jack and M-M RJ45 jumper kit	20

Notes:

Prices in US\$, subject to change without notice.

Pathport Unos are available in black or stainless steel finish - add BL or SS to specify

Pathport Manager 5 configuration software is available as a free download from our website